

VC Series Zone Valves

BALANCED 2-WAY AND 3-WAY HYDRONIC VALVES

PRODUCT DATA

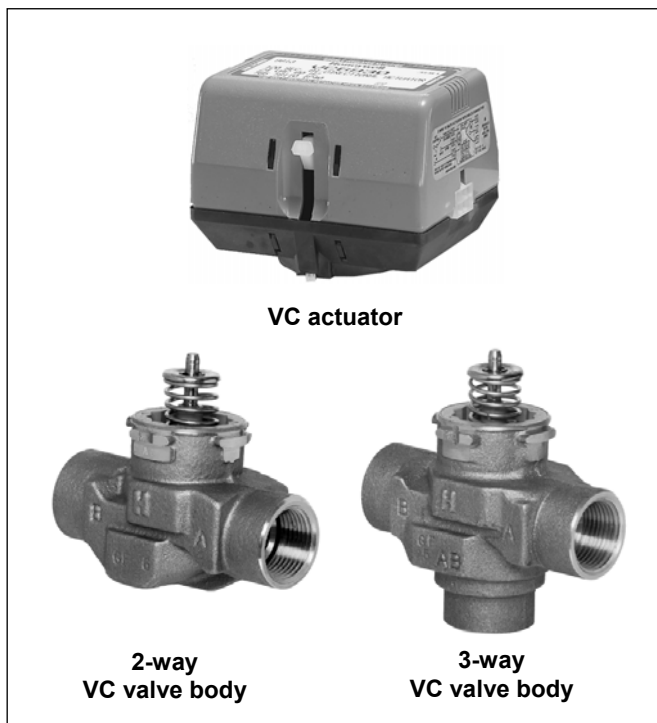

VC actuator

2-way
VC valve body

3-way
VC valve body

Application

Honeywell VC Series balanced 2-position hydronic valves are used in domestic and small commercial heating and cooling applications to control the flow of hot and/or cold water. They consist of an actuator, valve and a cartridge assembly.

2-way valves are designed for on-off zone control of domestic systems. 3-way valves can be piped for either diverting or mixing valve applications in domestic central heating and/or cooling systems. Both versions can be used to control individual fan coil, radiator, space heater or convector applications. Depending on the model selected they can be controlled by a low or line voltage SPST or SPDT controller such as a room thermostat, aquastat or flow switch.

VC Series hydronic valves are designed to take advantage of sinusoidal valve actuator travel, and therefore operate silently and reduce water hammer. Through internal logic the actuator only takes power while driving the valve to the commanded position.

The actuator head is removable without affecting the integrity of the water system. All actuator versions are interchangeable with any valve body, offering the highest flexibility for boiler production line assembly, and maintenance. The valve piston construction allows for port sealing that is independent of the differential pressure across the valve. Flow through the 2-way valve can be in either direction, so the ports are not designated. 3-way valves are suitable for both diverting water from AB to A or B, and from A or B to AB.

Design

VC Series zone valves consist of:

- 2-way or 3-way valve housing available with various connection ends
- Spindle and cartridge assembly
- Actuator with cable or Molex™ socket
- Pipe fittings (most versions)

Materials

- Valve housing made of bronze
- Spindle made of stainless steel
- Cartridge made of Ryton™ (polyphenylene sulphide) and Noryl™ (polyphenylene oxide)
- O-ring seals made of EPDM rubber
- Actuator cover made of Noryl™ (94V-0)
- Actuator base made of Ryton™ (94V-0)

Features

- **Rugged design**
- **Control by a low or line voltage SPST or SPDT controller**
- **Minimal actuator power consumption**
- **Pressure differential up to 4 bar**
- **Double insulated actuator**
- **Quick connect electrical connections**
- **Quick and easy replacement of moving parts**
- **Actuator head installation does not require draining of the system**
- **High flow rate capacity**

Specifications

Medium	Water or water-glycol mixture (max. 50% glycol content), quality to VDI 2035	Voltage	24 V, 50-60 Hz (blue label) 200-240 V, 50-60 Hz (red label)
pH-value	8...9.5	Power consumption	4 VA (when valve position changes)
Operating temperature	1...95°C (34...203°F) 120°C (248°F) short duration peak	Auxiliary switch rating	1.0 A @ 250 V, 50-60 Hz (minimum 0.05 A @ 24 Vdc)
Ambient temperature	max. 65°C (149°F)	Nominal timing	Valve opens in 7 seconds (20% faster for 60 Hz)
Operating pressure	max. 20 bar (290 psi) static max. 100 bar (1,450 psi) burst	Electrical termination	1. Molex™ socket: requires mating connector, alternatively 2. With integral 1 m leadwire
Differential pressure	max. 4 bar (58 psi)	Shipping temperature	-40...65°C (-40...149°F)
k_{vs} (cv)-values	see chapter "Dimensions" below	Humidity rating	5...95% RH (non-condensing)
Flow	2-way: flow can be in either direction. When actuator is not mounted valve is in closed position 3-way: bottom port is marked AB. End ports are marked A and B. When actuator is not mounted port A is closed.	Atmosphere	non-corrosive, non-explosive

Function

VC Series 2-position hydronic valves are used in domestic and small commercial applications to control the flow of hot and/or cold water. They consist of an actuator, valve and a cartridge assembly. All moving and sealing parts of the valve are constructed in the cartridge assembly. The ports are sealed with O-rings on the outer surface of the piston.

When the valve stem is driven down to open port A the water will flow through the hollow piston to the other port. In case of

a 3-way valve with the piston driven down port B is sealed, allowing flow between port AB and port A. With the stem up the flow is between port AB and port B.

The valve family offers a variety of versions of pipe connections to suit the different applications. The valve pressure loss characteristic is dependent on the pipe connections/ dimensions. For the actual valve rating please refer to the specification section.

2-way valve

With an SPDT (3-wire) actuator

On a call for heat, the NO controller contacts close and the valve opens. When the valve is fully open, the cam closes switch SW1 and opens switch SW2. When the need for heat is satisfied the NC controller contacts close, energising the valve through SW1 and closing the valve. When the valve is fully closed, the cam closes SW2 and opens SW1. The valve is ready for the next call for heat.

With an SPST (2-wire and common) actuator

On a call for heat, the controller contacts close, RLY1 is energized making the NO contacts in switch SW3 causing the valve to open. When the valve reaches the fully open position the cam closes switch SW1 and opens switch SW2. When the need for heat is satisfied, the controller contacts open, RLY1 is de-energized and the valve motor is driven through SW1 and the NC contacts of SW3. When the valve reaches the fully closed position, the cam closes SW2 and opens SW1. The valve is ready for the next call for heat.

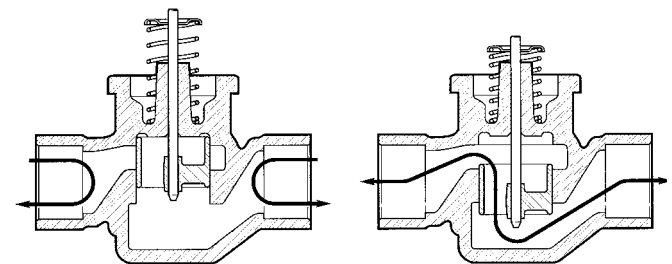

Fig. 1. Fluid flow through 2-way VC valve

3-way diverter valve

With an SPDT (3-wire) actuator

On a call for heat, the NO controller contacts close, the valve closes port B and opens port A. When port A is in the fully open position the cam closes limit switch SW1 and opens limit switch SW2. When the need for heat is satisfied the NC controller contacts close, energising the valve through SW1, causing port A to close. When port A is fully closed the cam closes SW2 and opens SW1. The valve is ready for the next call for heat.

With an SPST (2-wire and common) actuator

On a call for heat the controller contacts close, RLY1 is energized making the NO contacts in switch SW3, causing port B to close and port A to open. When port A reaches the fully open position the cam closes switch SW1 and opens switch SW2. When the need for heat is satisfied, the controller contacts open. RLY1 is de-energized making the NC contacts in SW3 and port A is driven closed through SW1 and the NC contacts of SW3. When port A is in the fully closed position the cam closes SW2 and opens SW1. The valve is ready for the next call for heat.

For both types of actuator a power failure will leave the valve at the position it was in when interrupted. When power is restored, the valve will respond to controller demand.

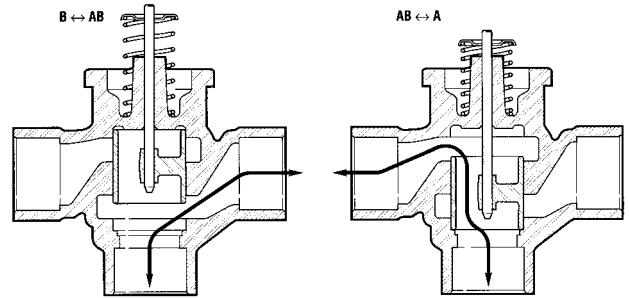

Fig. 2. Fluid flow through 3-way VC valve

Wiring

Figures 3 and 4 show wiring connections for 2-way and 3-way valves. Port A open and closed denotes valve open and closed for 2-way, and AB-A open and AB-B open for 3-way valves respectively. A means for disconnection from the supply having a contact separation of at least 3 mm in all

poles must be incorporated in the fixed wiring. On Molex™ connector models, actuator and auxiliary switch voltages must be the same to meet the approval requirement. For mixed voltages, the cable assembly version is recommended.

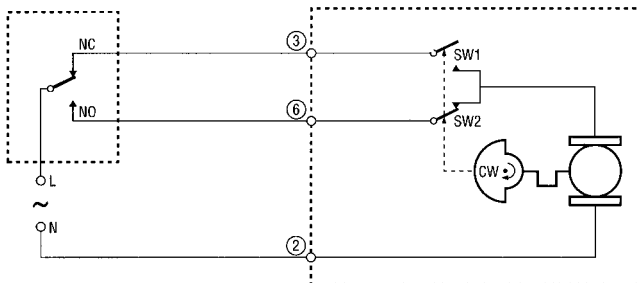

Fig. 3. Logic sequence diagram with 3-wire actuator for SPDT controller

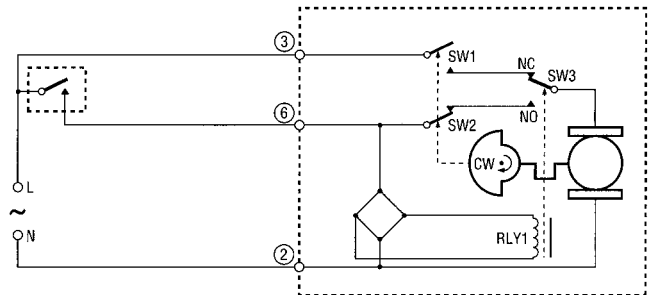

Fig. 4. Logic sequence diagram with 2-wire + common actuator for SPST controller

Dimensions

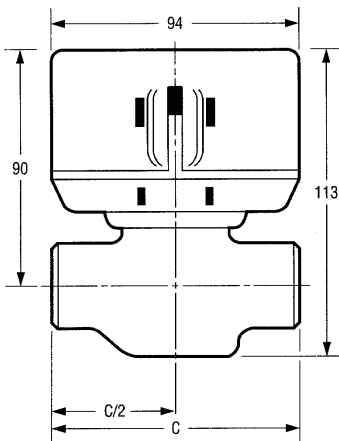

Fig. 5. 2-way VC valve

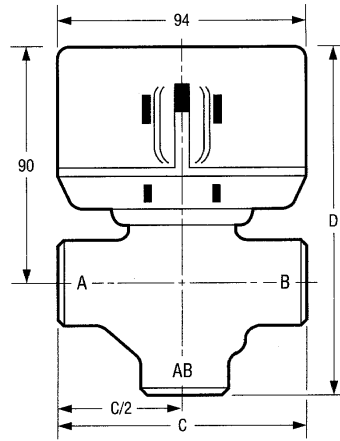
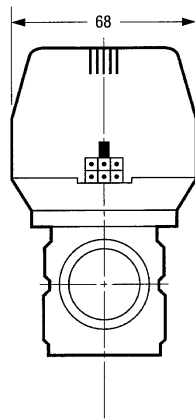

Fig. 6. 3-way VC valve

Table 1. Dimensions and kvs-value

Body	2-way VC valve		3-way VC valve		
	C	kvs-value	C	D	kvs-value
15mm compression	98	3.4	98	136	4.3
22mm compression*	112	6.8	112	140	8.6
28mm compression*	112	7.7	112	140	8.6
1/2" BSPP (external)	98	3.4	98	136	4.3
3/4" BSPP	94	6.8	94	130	7.7
1" BSPP	94	7.7	94	136	8.6
1/2" sweat	98	3.4	98	136	4.3
3/4" sweat	94	6.8	94	132	8.6
1" sweat	94	8.6	94	136	8.6

NOTE: All dimensions in mm

* Includes compression nuts and olives

Ordering Information

Use the Valve Selection Chart to find the right version. The Valve Selection Chart provides the necessary information to put together the OS-No. (OS=Ordering System). Example with OS-No. VC6012MP6000E:

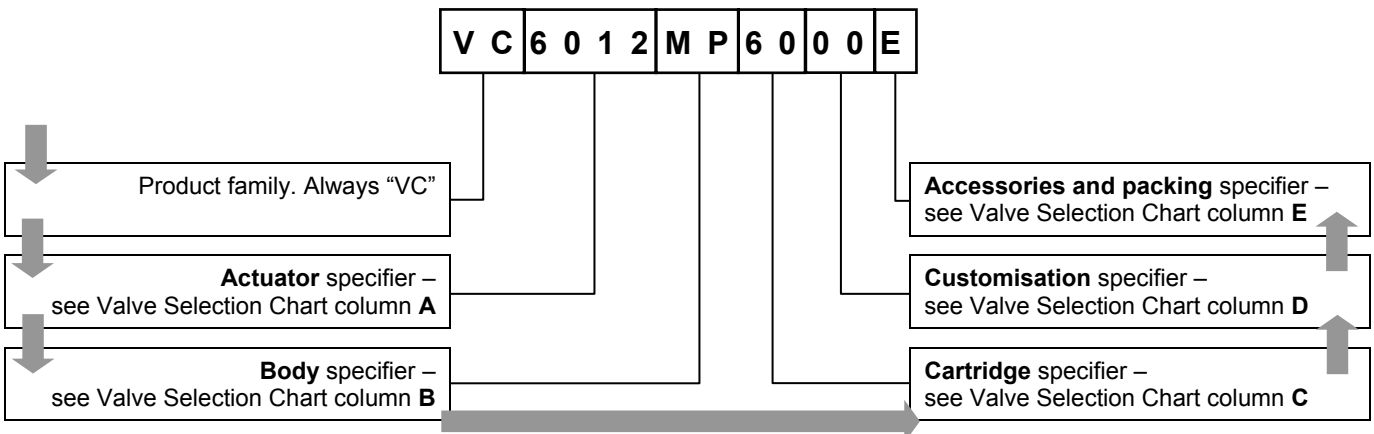

Valve Selection Chart

A Actuator		B Body		C Cartridge		D Customisation		E Packing	
Description	Code	Description	Code	k _{vs} -value	Code	Description	Code	Description	Code
24V (50...60Hz) 3-wire for SPDT stat. - with Molex™ socket - with 1,000mm cable	2010 2011	1/2" sweat 1/2" BSPP (internal thread)* 22mm compression fitting** 3/4" BSPP (external thread)	AA AF AG AH	3.0 3.0 5.3 5.3	10 10 10 10	00 Standard designation (no customisation)	— Unit pack (10 per overpack) Bulk pack (10 per unit)	— B E	
3-wire for SPDT stat. (w/SPDT aux. switch) - with Molex™ socket - with 1,000mm cable	2610 2611	3/4" BSPP (internal thread) 3/4" sweat 28mm compression fitting**	AJ AM AN	5.3 5.0 6.0	10 10 10	01...99 Customer special assigned by Honeywell	Egg crate (20 actuators or 10 bodies per crate)	E	
2-wire + com for SPST stat. - with Molex™ socket - with 1,000mm cable	8010 8011	1" BSPP (internal thread) 1" BSPP (external thread)	AP AQ	6.0 6.0	10 10				
2-wire + com for SPST stat. (w/SPDT aux. switch) - with Molex™ socket - with 1,000mm cable	8610 8611	1" sweat	AS	6.0	10				
200...240V (50...60Hz) 3-wire for SPDT stat. - with Molex™ socket - with 1,000mm cable	6012 6013	1/2" sweat 1/2" BSPP (internal thread)* 22mm compression fitting** 3/4" BSPP (external thread) 3/4" BSPP (internal thread) 3/4" sweat	MA ME MF MG MH ML	3.6 3.4 7.1 6.9 7.0 6.4	60 60 60 60 60 60				
3-wire for SPDT stat. (w/SPDT aux. switch) - with Molex™ socket - with 1,000mm cable	6612 6613	28mm compression fitting** 1" BSPP (internal thread) 1" BSPP (external thread)	MM MP MQ	7.7 7.7 7.7	60 60 60				
2-wire + com for SPST stat. - with Molex™ socket - with 1,000mm cable	4012 4013	1" sweat	MS	7.7	60				
2-wire + com for SPST stat. (w/SPDT aux. switch) - with Molex™ socket - with 1,000mm cable	4612 4613	* Valve end fittings are internally machined to accept 15mm compression fittings ** Compression fittings included							
No actuator (body only)	Z	No body (actuator only)		n/a	ZZ				

Installation

WARNING

Installer must be a trained, experienced service person.

When installing this product:

- Read these instructions carefully. Failure to follow them could damage the product or cause a hazardous condition.
- Check the ratings given in the instructions and on the product to make sure it is suitable for your application.
- Always conduct a thorough checkout after installation.

CAUTION

- Disconnect power supply before wire connection to prevent electrical shock and equipment damage.
- It is advisable to remove the actuator head from the valve body for ease of installation. Fit the actuator head in the most convenient position for wiring.
- On sweat fitted valves, the cartridge is shipped loose or is removed to avoid being damaged during the solder operation.
- On 24 V systems, never short circuit the valve coil terminals. This may burn out the heat anticipator in the thermostat.
- To remove the actuator head 25 mm clearance is needed above the actuator.

Plumbing

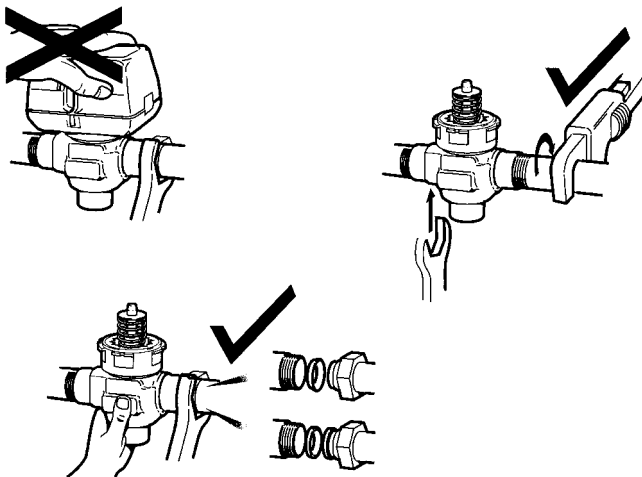

Fig. 7. Plumbing

The valve may be plumbed in any angle but preferably not with the actuator head below the horizontal level of the valve body. Make sure there is enough room around the actuator head for servicing or replacement.

When used to form part of a central heating system, do not locate it where it will block the system vent, cold feed or any bypass when the valve is closed.

Mount the valve directly in the tube or pipe. Do not grip actuator head while making and tightening plumbing connections. Either hold valve body in your hand or attach adjustable spanner across the hexagonal or flat faces on the valve body.

Compression models

For compression fitted models, tighten the compression nuts enough to make a watertight seal. Take care not to overtighten.

To install a replacement actuator head

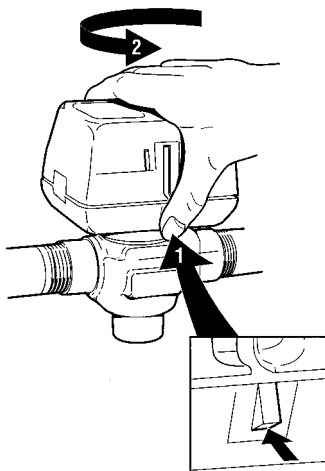

Fig. 8. Latch mechanism

Important

Installation of a new actuator head does not require draining the system providing the valve body and cartridge assembly remain in the pipeline.

1. Disconnect power supply before servicing to avoid electrical shock or equipment damage.
2. Disconnect leadwires to actuator head, or depress tab on Molex™ connector and remove. Where appropriate, label wires for rewiring.
3. The actuator head is automatically latched to valve (see figure 8). To remove, lift up on the latch mechanism located directly below the red manual open lever. Press the actuator head down towards the body with moderate hand force and turn counter-clockwise by 1/8 turn (45 degrees) simultaneously. Lift the actuator head off the valve body.

NOTE: Actuator can also be installed at right angles to valve body but in this position latch mechanism is not engaged.

4. Install the new actuator head by reversing process in (3).
5. Reconnect leadwires or Molex™ connector.
6. Restore power.

Adjustment and Testing

Manual Opener

The manual opener can be manipulated when in the up position. The motorized valve can be opened by firmly pushing the red manual lever down to midway and in (only possible if the actuator is in the upper position). This holds all ports in the open position, and with auxiliary switch models the NO switch is closed. Ports A and B of 3-way valves are opened. This 'manual open' position may be used for filling, venting or draining the system, or for opening the valve in case of power failure. The valve can be restored manually to the closed position by depressing the red manual lever lightly and then pulling it out. The valve actuator returns to the automatic position when power is restored.

Checkout

1. Raise the set point of the thermostat above room temperature to initiate a call for heat. Valve position indicator should move downward to the open position.
2. For all auxiliary switch models, monitor the control devices. 2-way valve: check that the valve opens, the auxiliary switch (if present) closes, and at the end of the opening stroke the circuit to the circulator or another valve is made. 3-way valve: check that port A opens, port B closes, the auxiliary switch (if present) operates, and at the end of the opening stroke the circuit to the circulator or another valve is made.
3. Lower the set point of the thermostat below room temperature.
4. Observe the control devices.
2-way valve: check that the valve closes and all auxiliary equipment stops.
3-way valve: check that port A closes and all auxiliary equipment stops.

Service



This valve should be serviced by a trained, experienced service person.

1. If the valve is leaking, drain system or isolate valve from the system.
2. Check to see if the cartridge needs to be replaced.
3. If the gear train or the motor is damaged, replace the actuator assembly.

NOTE: Honeywell hydronic valves are designed and tested for silent operation in properly designed and installed systems. However, water noises may occur as a result of excessive water velocity. Piping noises may occur in high temperature (over 100 C) systems with insufficient water pressure.

Flow Diagrams

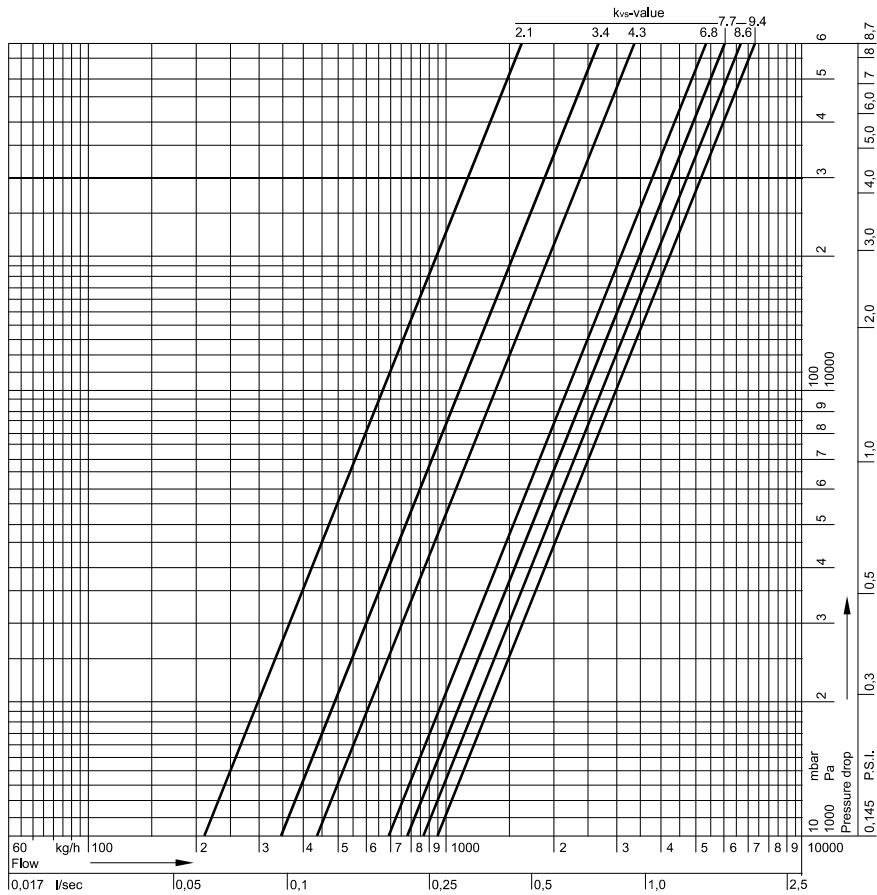

Fig. 9. Valve pressure loss characteristic

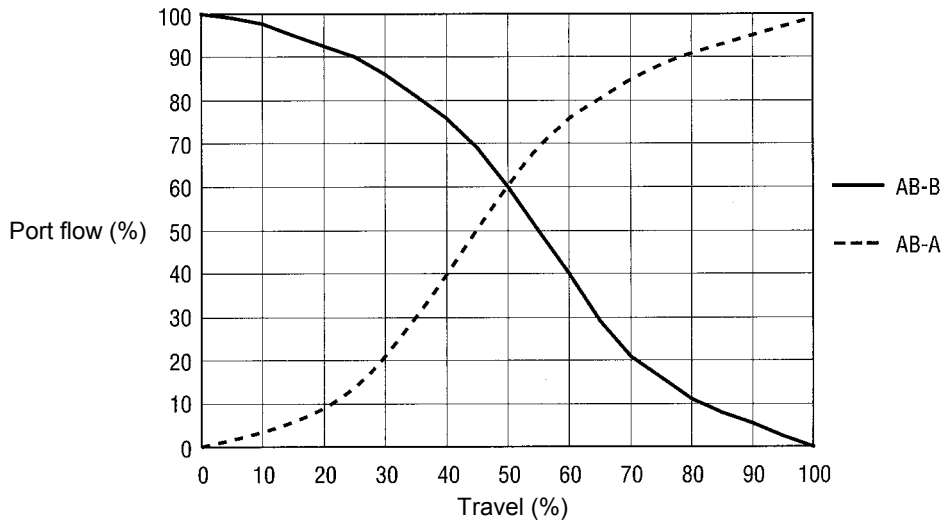

Fig. 10. Typical 3-way valve diverting characteristic at constant pressure on port AB

ACS Control Products
 Honeywell GmbH
 Möhnstraße 55
 59755 Arnsberg, Germany
 Phone: +49 (2932) 9880
 Fax: +49 (2932) 988324
 www.honeywell.com

EN0H-0327GE25 R0206
 February 2006
 © 2005 Honeywell International Inc.
 Subject to change • All rights reserved
 Manufactured for and on behalf of the Environmental and Combustion
 Controls Division of Honeywell Technologies Sàrl, Ecublens,
 Route du Bois 37, Switzerland or by its Authorized Representative.

Honeywell