

MODEL	STROKE TIME FOR CONTROLLI VALVES			POWER SUPPLY (Vac)	CONTROL
	16,5 mm	25 mm	45 mm		
MVL56F	26 s	40 s	70 s	24 V	proportional
	300/60 s	300/60 s	300/60 s		floating



APPLICATION AND USE

MVL actuators have linear characteristic (linear ratio between input signal and valve coupling joint movement). They are used for fluid control in air-conditioning and heating systems and in industrial processes. The control signal can be set as proportional or floating by acting on the dip switches. They are designed for direct coupling on all CONTROLLI globe valves and they may also be used easily on other manufacturers' valves having a stroke between 9 and 50 mm.

OPERATION

The actuators are equipped with bidirectional electrical motor, they self-adjust according to the valve stroke, granting a constant torque at the valve mechanical stroke ends regardless of their position.

All models are also provided with a feedback output signal indicating the valve position.

MANUFACTURING CHARACTERISTICS

The actuator consists in a die-cast aluminium housing, which includes mounting bracket for connection to valve body.

Reduction gears supported by ball bearings. Movement is transmitted to a rack-and-pinion mechanism connected to the valve stem through a suitable joint.

Internal electronic card with easily accessible terminals for electrical connections.

The manual control knob is placed on the front part of the actuator; the knob is in thermoplastic material.

The actuator is maintenance-free.

POSSIBLE COMBINATIONS AND CONNECTIONS

The actuator can be connected to any controller, providing that the relevant output signal complies with the requirements at "Technical Characteristics" paragraph. In particular it can be connected to CONTROLLI 500-line controllers.

TECHNICAL CHARACTERISTICS

Power supply	24 Vac, $\pm 10\%$
Consumption	12 VA
Dimensioning	15 VA
Frequency	50...60 Hz
Stroke	9...50 mm
Stroke time	See available models
Force	1500 N
Temperature	
- operating	-15T 50 °C
- storage	-25T 65 °C
Allowed room humidity	Class R according to DIN 40040
Terminal board	screw-type 1,5 mm ² wires
N. 2 conduit opening	plastic punchable, replaceable by PG 13,5 compression glands
Protection degree	IP 55 DIN 40050 (IEC 529) For highly polluted environments according to IEC 730-1(93)/6.5.3
Weight	4 Kg
Control signal	
Floating	2 SPST contacts
Proportional	
- voltage	0...10V (factory setting), 2...10V/ 4...7V/8...11V/1...5V/6...9V see MVLFS5 accessory
- current	
Output indication	
G0-Y	2...10 Vdc (max 2 mA)
Voltage outside power supply output	
G0-G1	16 Vdc (max 25 mA)

The product complies with EMC 2004/108/CE directive according to the EN 61326-1:2006 standard.

ACCESSORIES

DMVL (only factory-mounted. To be ordered together with the actuator).

2 auxiliary microswitches (SPDT 10 (3) A-250V~) adjustable on the whole stroke. Microdisconnection type 1B according to IEC 730-1(93)/6.4.3.2. It is possible to place the cams so that the microswitches act according to the required position. Keep in mind that when the lever is on the cam protruding part, the contact is closed between b and c and open between c and a (see figure below).

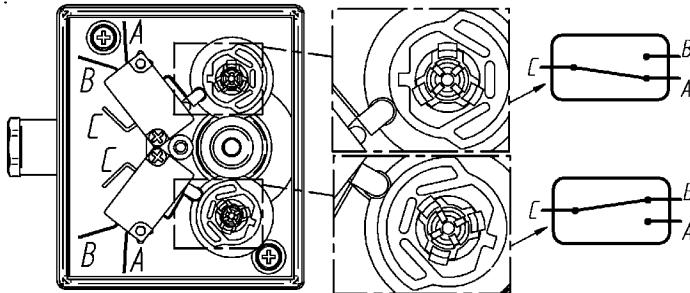

Make the electrical connections in compliance with the rules in force.

Attention: during operation, the cables must not interfere with the cams and the gears.

DMVF 2 stroke end microswitches with electronic control, not adjustable.

MVLFS5 Accessory for 4÷20 mA control signal.

This accessory is factory-supplied with the actuator.

MVLHT Valve body-actuator spacer reducing the actuator direct exposure in case of installation with high-temperature fluids.

Dimensions: Ø 120 mm; h = actuator height + 102 mm

245 Stem heater 24 V~, 50 W (for applications with fluid temperature <-10 °C)

AG31 Assembling kit for VMB and VSB valves.

INSTALLATION AND MOUNTING

The actuator can be mounted in the positions shown in Fig. 3. It is advisable to use the motorized valve with MVLHT spacer in order to reduce the actuator working temperature in case of fluids at high temperatures (approximately > 120 °C) in the valve body. For fluids over 160 °C avoid mounting the actuator in vertical position on the valve so as to avoid the direct exposure to heat sources.

Carry out the electrical connections by removing the cover, in compliance with the rules in force. For valve mounting, follow the assembly instructions inside the package.

These actuators are factory-supplied with 0...10 V- control signal. To select different ranges, move the "DIP" microswitches (see fig. 1 and 2).

For 4...20 mA range it is necessary to select 2...10 V range and mount the resistance as shown on installation instructions of the actuator.

To reverse the action direction, move the DIP 7 from OFF to ON.

ELECTRONIC BOARD

OPERATION MODE SELECTION (CONFIGURATION DIP)

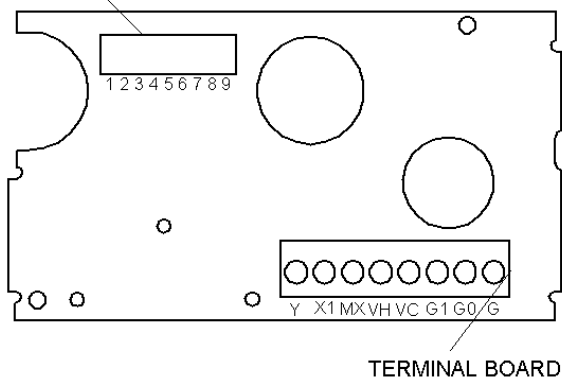

FIG. 1

WIRING DIAGRAMS

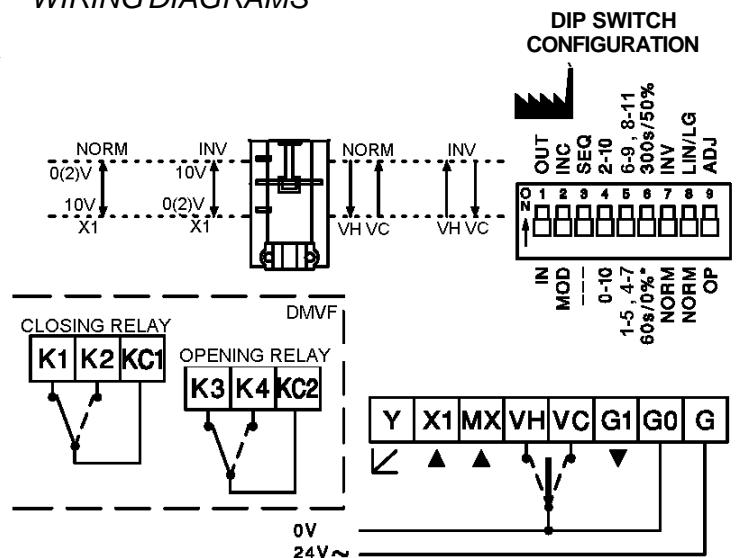

FIG. 2

MOUNTING POSITIONS

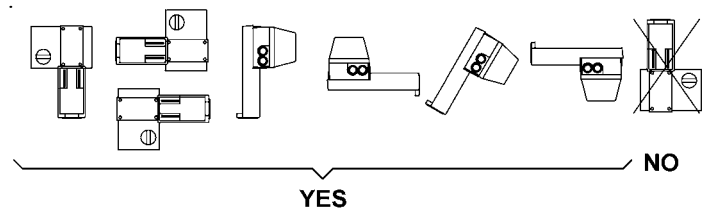
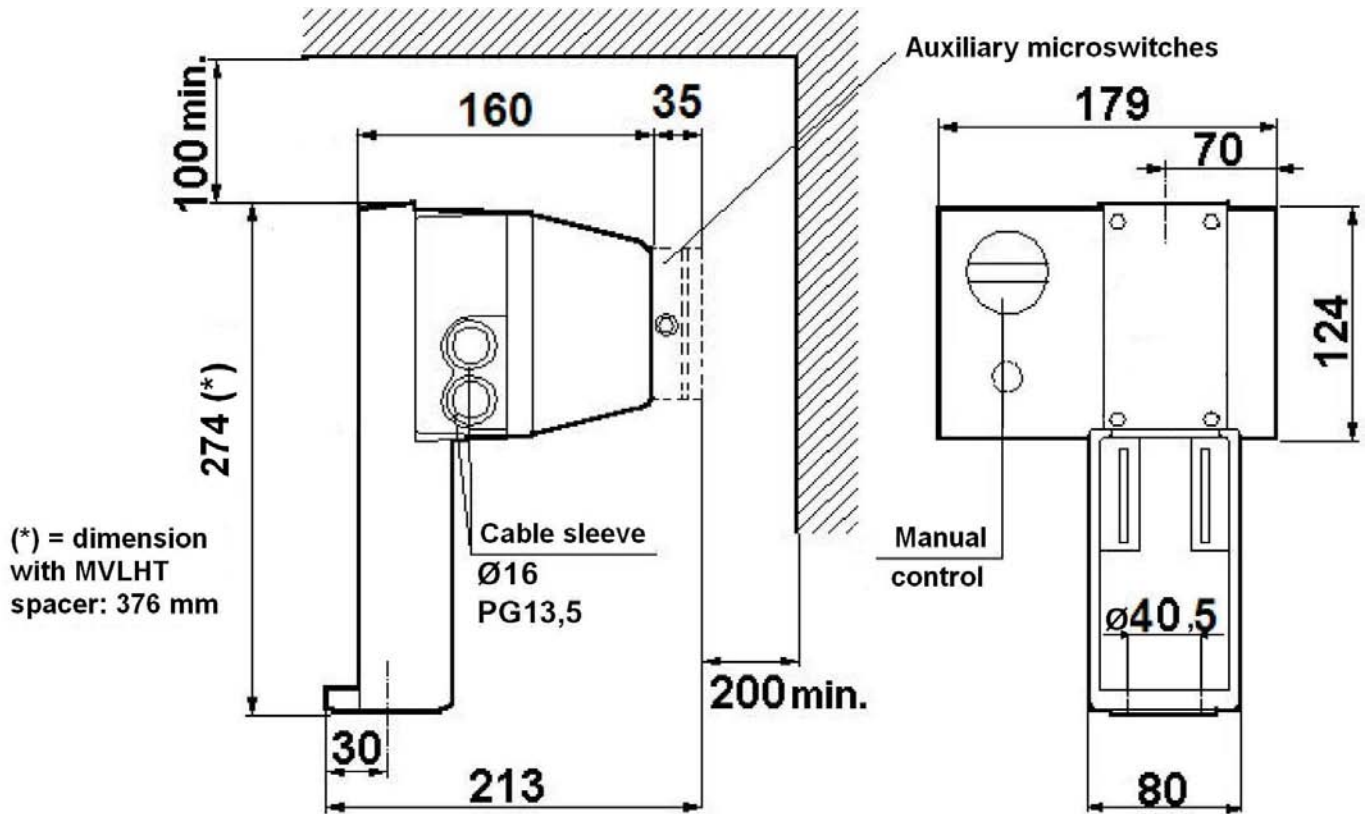

FIG. 3

OVERALL DIMENSIONS (mm)



The performance stated in this sheet can be modified without any prior notice due to design improvement.



Automatic control system for:
air-conditioning/heating/industrial thermal process.